

Figure 1

**1. INTRODUCTION**

This instruction sheet covers the use of AMP\* Cover Lacing Fixture 91293-1 which is used with Manual Arbor Frame Assembly 58024-1 to apply discrete wires to AMPLIMITE .050 Series connectors and AMPMODU 50/50 grid connector wire lacing termination covers.

For detailed information on the setup of the arbor frame, refer to AMP Instruction Sheet 408-6923. For information on the connectors, refer to Catalog 82068. For information on the termination covers, refer to Catalog 82643.

**NOTE** *Dimensions on this sheet are in metric units [with U.S. customary units in brackets]. Figures are not drawn to scale.*

Reasons for reissue of this instruction sheet are provided in Section 6, REVISION SUMMARY.

**2. DESCRIPTION** (Figure 1)

The fixture consists of a slide assembly, a lacing fixture subassembly, and an upper tooling assembly containing two 50-position and two 100-position seating bars. Additional seating bars, purchased separately, are available for applying 26- and 68-position connectors.

The slide assembly consists of a slide body and a slide stop. The slide body mounts to the base of the manual arbor frame assembly and allows the lacing fixture subassembly to slide back into position under the upper tooling assembly. The slide stop, which is used to position the lacing fixture subassembly under the upper tooling assembly, is a thin bar of steel that is fastened to the back of the slide at one of two positions.

The lacing fixture subassembly consists of a U-shaped base with slots to hold the termination covers. Each slot has a stationary locator and an adjustable locator that permit proper positioning of the termination covers. Mounted onto the base are four combs (two inner combs and two outer combs), which are used to guide and hold the wires as they are pressed into the termination covers during the termination procedure.

On the underside of the base is a cable clamp which holds the jacketed cable while the wires from the cable are being laced into the combs.

The upper tooling assembly features a tool mount, a top plate, four seating bars, and two cutting blades. The inner seating bars push the wires at the inside edge of the termination cover. The center seating bars, which push the wires down inside the termination cover, must be installed to match the termination cover size being applied.

The cutting blades help push the wires downward at the outside edge of the connector, and then cut the wires nearly flush with the connector edge.

**3. TOOLING ASSEMBLY SETUP**

1. Place the slide body onto the base of the arbor frame, and align the screw holes in the bottom of the slide body with the holes in the base. Refer to Figure 2.
2. While holding the slide body in place, tilt the arbor frame and insert, but do not tighten, the four mounting screws.

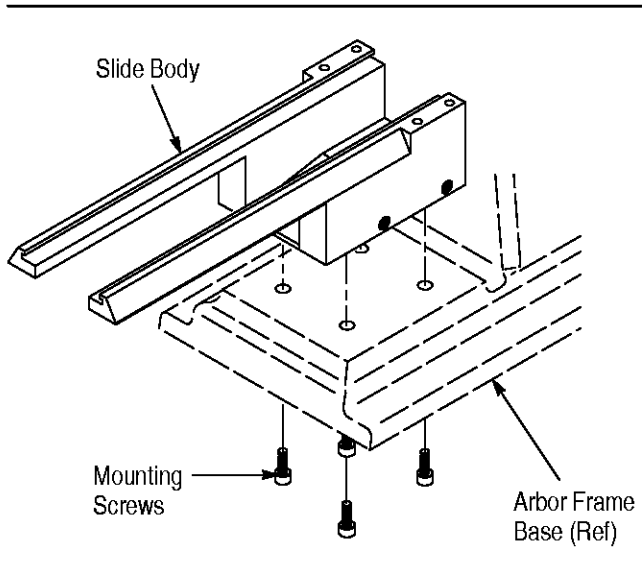

Figure 2

3. Remove the tool mount from the ram of the arbor frame assembly, if assembled.
4. Install the proper seating bars for the application as shown in Figure 3.

**NOTE** Be sure to locate the tabs on the seating bars toward the BACK of the arbor frame assembly.

5. Place the upper tooling assembly and tool mount onto the ram, and tighten the flat head screws. Refer to Figure 4.
6. Align the slide stop with the appropriate pair of mounting holes in the slide body, and insert and tighten the two mounting screws. Refer to Figure 5.

**NOTE** The forward-most mounting holes in the slide are for 26- and 50-position termination covers, and the rear-most holes are for 68- and 100-position termination covers.

7. Place the lacing fixture subassembly onto the slide body as shown in Figure 5.

Orientation of 68-Position Seating Bars

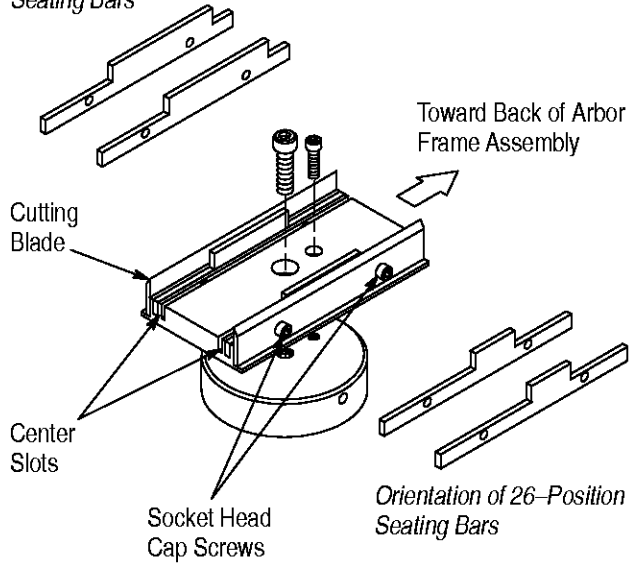

Figure 3

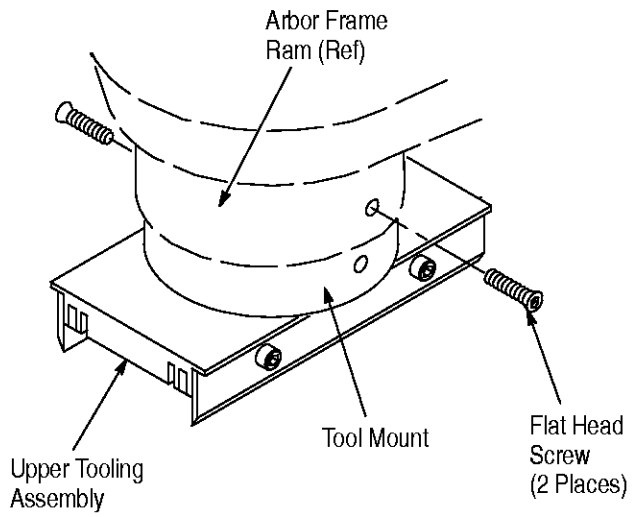

Figure 4

8. Slide the lacing fixture subassembly back against the slide stop.
9. Slowly lower the upper tooling assembly until it comes in contact with the lacing fixture subassembly. If the cutting blades strike the stationary or adjustable locators, then move the slide assembly until the cutting blades clear the locators and bottom on the base of the lacing fixture subassembly.
10. With the upper tooling assembly still lowered onto the lacing fixture subassembly, tilt the arbor frame assembly and tighten the slide assembly mounting screws.

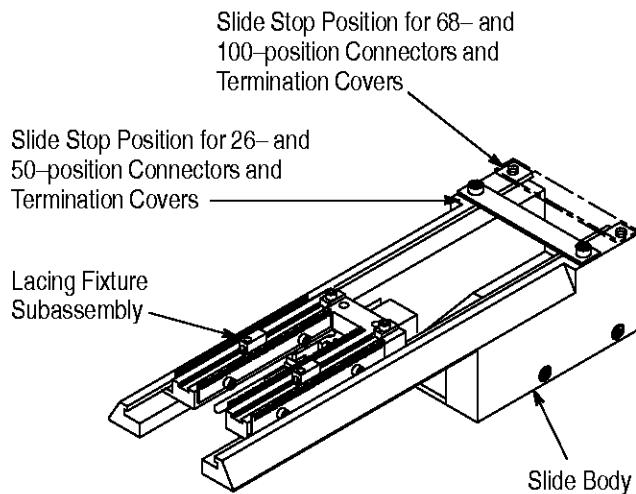

Figure 5

11. Return the arbor frame assembly to the correct operating position, then carefully raise the ram and upper tooling assembly until the upper tooling assembly touches the frame.

12. Carefully lower the ram and upper tooling assembly to double check that the cutting blades clear the locators.

13. Secure the arbor frame assembly to the work surface according to instructions supplied with the frame assembly, or if using the bend stand (supplied with lacing fixture), secure the bench stand to the work surface. Remove the lacing fixture subassembly from the slide, and place it into the bench stand. Secure the subassembly by tightening the thumbscrew. Refer to Figure 6.

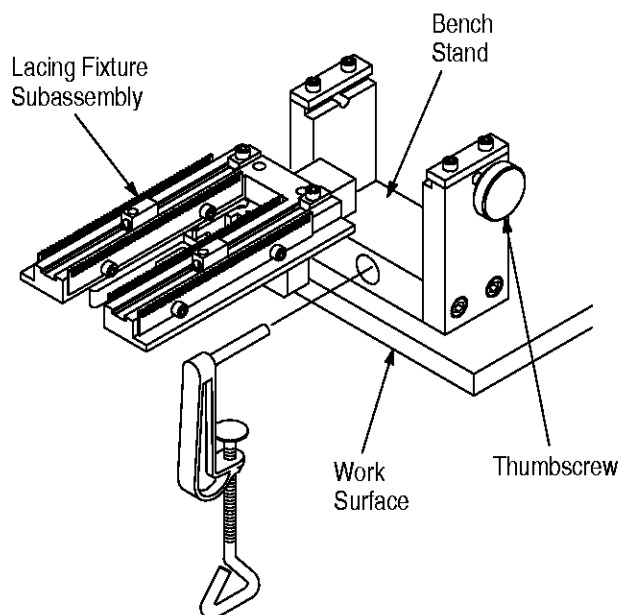

Figure 6

#### 4. SEATING PROCEDURE

After tooling is properly installed and secured to the work surface, proceed as follows:

1. Loosen the adjustable locators in each slot of the lacing fixture subassembly base, then move the locators so that the covers will fit into the lacing fixture subassembly slots.

#### NOTE

*Due to the keying feature on the stationary locators, the covers will only fit with the stepped edge of the cover toward the inside of the lacing fixture subassembly.*

2. Place the termination covers in their respective slots.
3. Slide the adjustable locators toward the back of the assembly until the locators touch the covers and the ball plunger in each adjustable locator sufficiently secures the covers.
4. Prepare the cable for use as described in the instructions supplied with the connector or termination cover.
5. Open the cable clamp by opening the latch. Refer to Figure 7.

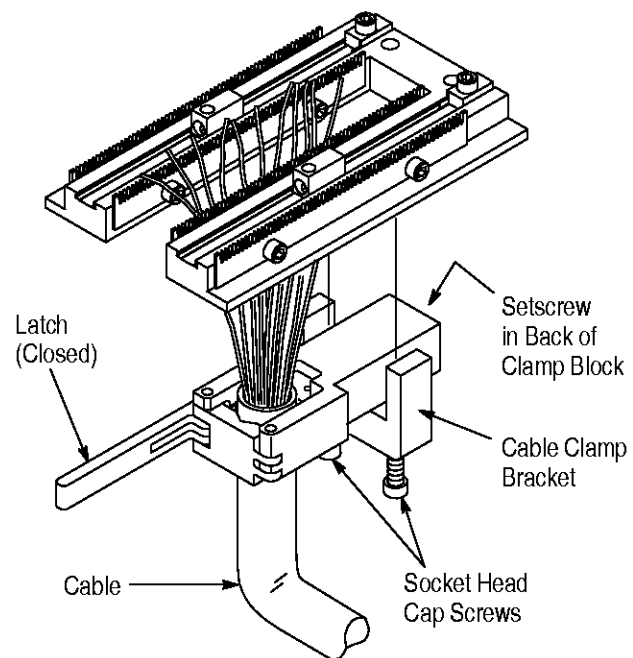

Figure 7

6. Place a properly prepared cable into the clamp, with the wires protruding upward through the lacing fixture, and with the edge of the cable jacket approximately even with the top edge of the cable clamp.

7. Close the latch by hooking over the pin on the clamp.

**NOTE**

If the clamp is too tight or too loose, adjust the clamp by moving the jaw using the setscrew located in the back of the clamp block. Refer to Figure 7.

8. Position the cable clamp so that the cable bundle is centrally located on the termination cover. To position the clamp, loosen, but do not remove, the socket head cap screws in the cable clamp bracket and slide the clamp to the desired position. Refer to Figure 7.

9. After the cable is secured, untwist the wires (if twisted) and lace the individual wires into the wire slots. Pull each wire into the proper slot in the comb. Continue pulling downward on each wire until the wire is snug in the slot. When in place, the wire should not pop out of the slot.

**NOTE**

For ease of termination, start at one end of the covers and work toward the opposite end.

10. After all of the wires are laced, slide the lacing fixture subassembly back under the upper tooling assembly until it butts against the stop.

**NOTE**

If using the bench stand, remove the lacing fixture subassembly and place it into the slide of the arbor frame assembly. Slide the lacing fixture subassembly back until it butts against the stop.

11. Pull the arbor frame handle downward to seat and cut the wires. The action of the wires entering the clips on the termination covers should be felt through the handles as a slight “snap.”

12. While maintaining pressure on the arbor frame handle, remove the cut wire ends protruding from the lacing fixture subassembly.

13. Lift the arbor frame handle to raise the upper tooling assembly. Slide the lacing fixture subassembly out, then open the cable clamp.

14. Carefully push upward on the cable, and remove the covers from the lacing fixture subassembly.

**NOTE**

If necessary, a pointed instrument can be used to help remove the wires from the inside combs. Take care to avoid damaging the insulation or pulling the wires out of the clip in the termination cover.

15. After the wires are correctly seated into the termination covers, the covers can be seated onto the connector. For cover seating procedure, refer to Instruction Sheet 408-9820.

## 5. REPLACEABLE PARTS

The tooling described is available as follows:

ITEM	DESCRIPTION
Cover Lacing Fixture 91293-1	Includes slide assembly, upper tooling assembly, two 50-position seating bars, two 100-position seating bars, and Lacing Fixture Subassembly 543481-1
Lacing Fixture Subassembly 543481-1	Includes bench stand and clamp
Seating Bar 543494-2	26-position seating bar
Seating Bar 543494-1	50-position seating bar
Seating Bar 543502-2	68-position seating bar
Seating Bar 543502-1	100-position seating bar

## 6. REVISION SUMMARY

Revisions to this instruction sheet per EC 0990-0774-97 include:

- Modified Figure 7
- Added replaceable parts to Section 5